

4 Finger Parallel Style Air Gripper

Series MHS4

Size: 16, 20, 25, 32, 40, 50, 63



Refer to page 12-13-25 for solid state switch with pre-wire connector.

How to Order

Bore size

ø16 to ø25

MHS 4 - 20 D - M9N

Number of fingers	4	4 fingers
	Bore size	
	16	16 mm
	20	20 mm
	25	25 mm

Action	D	Double acting
--------	---	---------------

Number of auto switches	Nil	2 pcs.
	S	1 pc.

Auto switch	Nil	Without auto switch (Built-in magnet)
-------------	-----	---------------------------------------

* For the applicable auto switch model, refer to the table below.

Applicable Auto Switch/Refer to page 12-13-1 for further information on auto switches

Type	Special function	Electrical entry	Indicator light	Wiring (Output)	Load voltage		Auto switch model		Lead wire length (m)*			Flexible lead wire (-61)	Applicable load		Pre-wire connector
					DC	AC	Electrical entry		0.5 (Nil)	3 (L)	5 (Z)		IC circuit	Relay, PLC	
							Perpendicular	In-line							
Solid state switch	—	Grommet	Yes	3-wire (NPN)	24 V	5 V	M9NV	M9N	●	●	○	Standard	—	—	○
				3-wire (PNP)		12 V	M9PV	M9P	●	●	○				○
				2-wire	12 V	M9BV	M9B	●	●	○	○				
	Water resistant (2-color indication)			2-wire	12 V	—	F9BA	—	●	○	○				

* Lead wire length symbols: 0.5 m ... Nil (Example) M9B
3 m ... L (Example) M9BL
5 m ... Z (Example) M9BZ

Note) Take note of hysteresis with 2-color indication type switches. Refer to "Auto Switch Hysteresis" on page 12-7-62.

* Auto switches marked with a "O" symbol are produced upon receipt of order.

Bore size

ø32 to ø63

MHS 4 - 50 D - Y59A

Number of fingers	4	4 fingers
	Bore size	
	32	32 mm
	40	40 mm
	50	50 mm
	63	63 mm

Action	D	Double acting
--------	---	---------------

Number of auto switches	Nil	2 pcs.
	S	1 pc.

Auto switch	Nil	Without auto switch (Built-in magnet)
-------------	-----	---------------------------------------

* For the applicable auto switch model, refer to the table below.

Applicable Auto Switch/Refer to page 12-13-1 for further information on auto switches

Type	Special function	Electrical entry	Indicator light	Wiring (Output)	Load voltage		Auto switch model		Lead wire length (m)*			Flexible lead wire (-61)	Applicable load		Pre-wire connector
					DC	AC	Electrical entry		0.5 (Nil)	3 (L)	5 (Z)		IC circuit	Relay, PLC	
							Perpendicular	In-line							
Solid state switch	—	Grommet	Yes	3-wire (NPN)	24 V	5 V, 12 V	Y69A	Y59A	●	●	○	Standard	—	—	○
				3-wire (PNP)		12 V	Y7PV	Y7P	●	●	○				○
				2-wire	12 V	Y69B	Y59B	●	●	○	○				
	Diagnosis (2-color indication)			3-wire (NPN)	24 V	5 V, 12 V	Y7NWV	Y7NW	●	●	○				○
				3-wire (PNP)		12 V	Y7PWV	Y7PW	●	●	○				○
				Water resistant (2-color indication)	2-wire	12 V	—	Y7BWV	Y7BW	●	●				○
							—	Y7BA	—	●	○	○			

* Lead wire length symbols: 0.5 m ... Nil (Example) Y59B
3 m ... L (Example) Y59BL
5 m ... Z (Example) Y59BZ

* Auto switches marked with a "O" symbol are produced upon receipt of order.

Note) Take note of hysteresis with 2-color indication type switches.

Refer to "Auto Switch Hysteresis" on page 12-7-62.

JIS Symbol

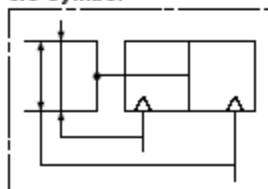

MHZ

MHF

MHL

MHR

MHK

MHS

MHC

MHT

MHY

MHW

MRHQ

Misc.

D-

20-

Series MHS4

Model/Specifications



Model	MHS4-16D	MHS4-20D	MHS4-25D	MHS4-32D	MHS4-40D	MHS4-50D	MHS4-63D	
Bore size (mm)	16	20	25	32	40	50	63	
Fluid	Air							
Operating pressure (MPa)	0.2 to 0.6			0.1 to 0.6				
Ambient and fluid temperature (°C)	-10 to 60							
Repeatability (mm)	±0.01							
Max. operating frequency (c.p.m.)	120			60				
Lubrication	Not required							
Action	Double acting							
Effective gripping force (N) at 0.5 MPa ⁽¹⁾	External grip	10	19	31	55	88	140	251
	Internal grip	12	21	35	61	97	153	268
Opening/Closing stroke (mm)	4	4	6	8	8	12	16	
Weight (g)	66	110	154	300	390	590	1,095	

Note) Values for $\phi 16$ to $\phi 25$ are with gripping point L = 20 mm, and for $\phi 32$ to $\phi 63$ with gripping point L = 30 mm.
Refer to the "Effective Gripping Force" data for the gripping force at each gripping position.

Construction

Closed condition

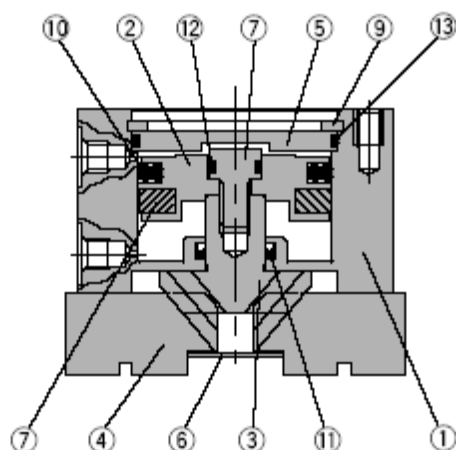

Open condition

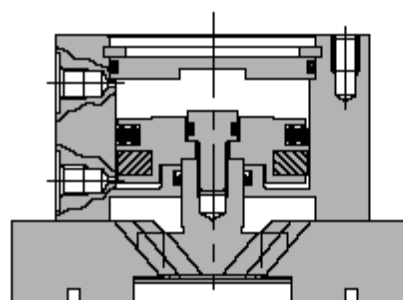

Component Parts

No.	Description	Material	Note
①	Body	Aluminum alloy	Hard anodized
②	Piston	Aluminum alloy	Hard anodized
③	Cam	Carbon steel	Heat treated, Specially treated
④	Finger	Carbon steel	Heat treated, Specially treated
⑤	Cap	Aluminum alloy	Hard anodized
⑥	End plate	Stainless steel	
⑦	Piston bolt	Stainless steel	

No.	Description	Material	Note
⑧	Rubber magnet	Synthetic rubber	
⑨	Type C snap ring	Carbon steel	Nickel plated
⑩	Piston seal	NBR	
⑪	Rod seal	NBR	
⑫	Gasket	NBR	
⑬	Gasket	NBR	

Replacement Parts

Description	MHS4-16D	MHS4-20D	MHS4-25D	MHS4-32D	MHS4-40D	MHS4-50D	MHS4-63D	Main parts
Seal kit	MHS16-PS	MHS20-PS	MHS25-PS	MHS32-PS	MHS40-PS	MHS50-PS	MHS63-PS	⑩⑪⑫⑬
Finger	P3316004	P3346104	P3316204	P3316304	P3316404	P3316504	P3316604	④
Cam	P3316043	P3316143	P3316243	P3316343	P3316443	P3316543	P3316643	③
Piston assembly	MHS-A1601	MHS-A2001	MHS-A2501	MHS-A3201	MHS-4001	MHS-5001	MHS-6301	②⑦⑧

* Order 4 pieces of fingers for one unit.

4 Finger Parallel Style Air Gripper Series MHS4

Gripping Point

- The workpiece gripping point distance should be within the gripping force ranges given for each pressure in the effective gripping force graphs below.
- If operated with the workpiece gripping point beyond the indicated ranges, an excessive offset load will be applied to the sliding section of the fingers, which can have an adverse effect on the service life of the product.

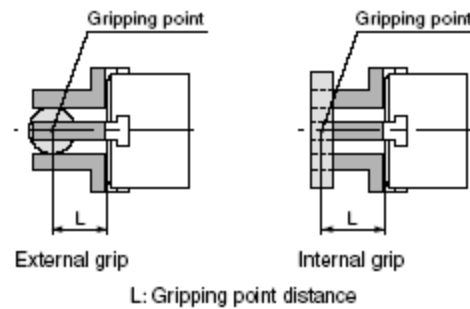

Effective Gripping Force

- Indication of effective gripping force
The gripping force shown in the tables represents the gripping force of one finger when all fingers and attachments are in contact with the workpiece. The gripping force of Series MHS4 is the same as Series MHS2 while one pair of opposite fingers is used to grip the workpiece and the other pair of fingers is used for positioning.

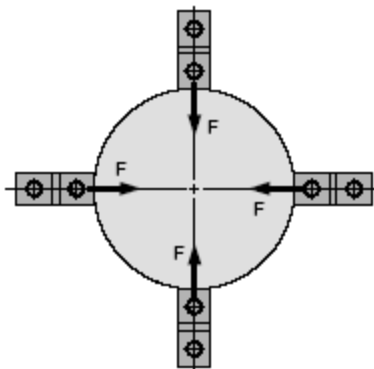

External grip

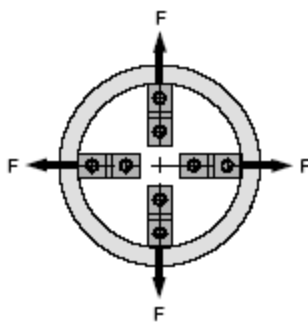

Internal grip

External Gripping Force

MHS4-16D

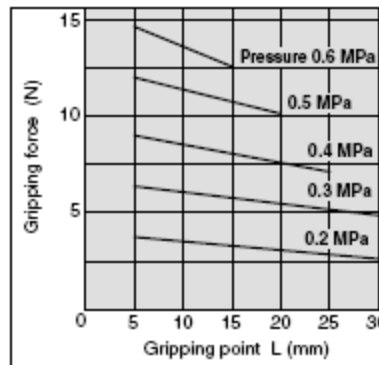

MHS4-20D

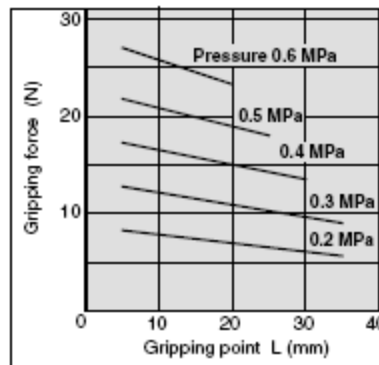

MHS4-25D

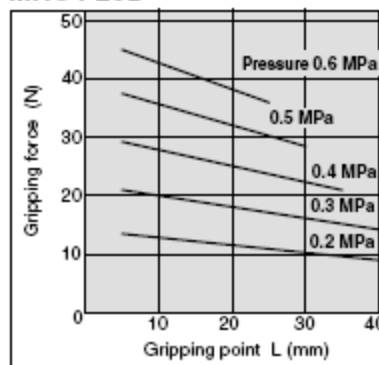

Internal Gripping Force

MHS4-16D

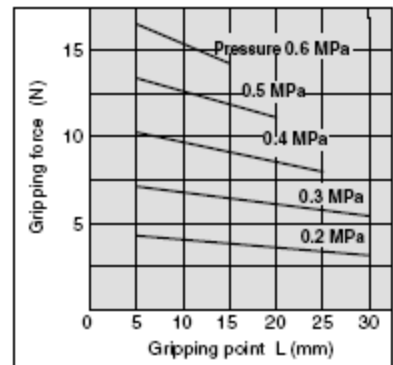

MHS4-20D

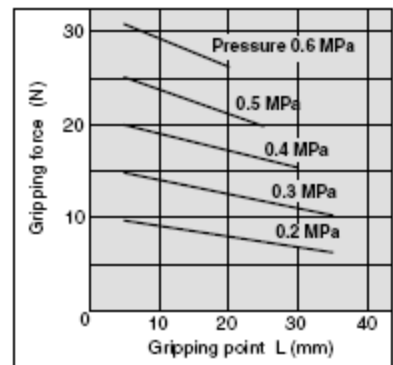

MHS4-25D

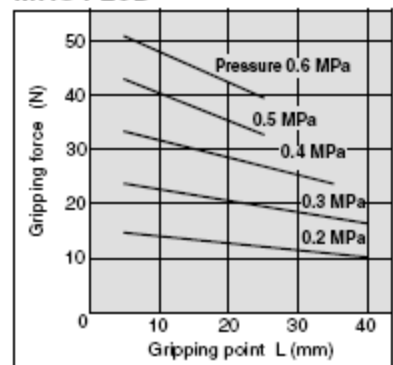

Series MHS4

Effective Gripping Force

- Indication of effective gripping force
The gripping force shown in the tables represents the gripping force of one finger when all fingers and attachments are in contact with the workpiece. The gripping force of Series MHS4 is the same as Series MHS2 while one pair of opposite fingers is used to grip the workpiece and the other pair of fingers is used for positioning.

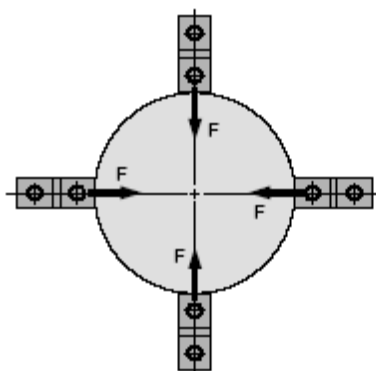

External grip

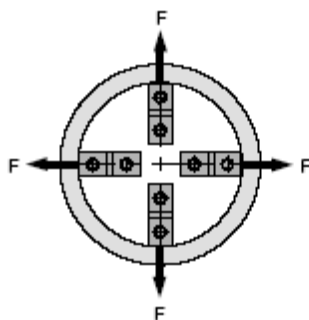

Internal grip

External Gripping Force

MHS4-32D

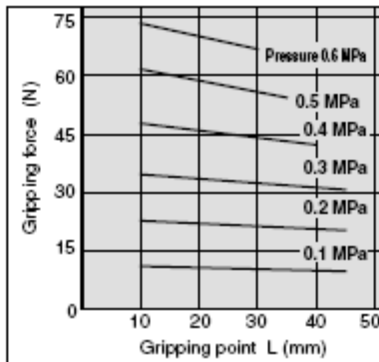

MHS4-40D

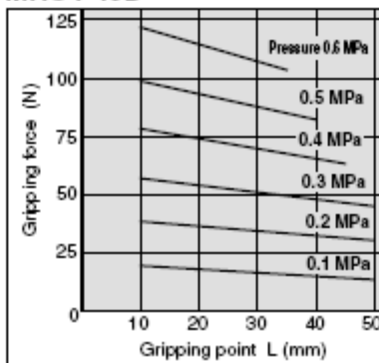

MHS4-50D

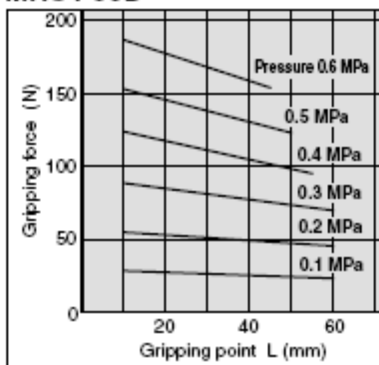

MHS4-63D

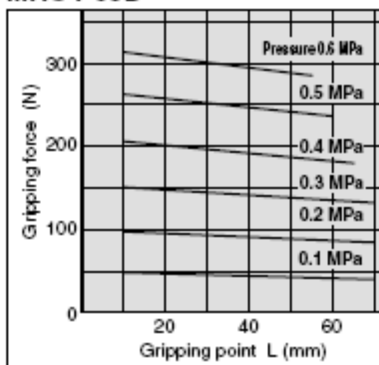

Internal Gripping Force

MHS4-32D

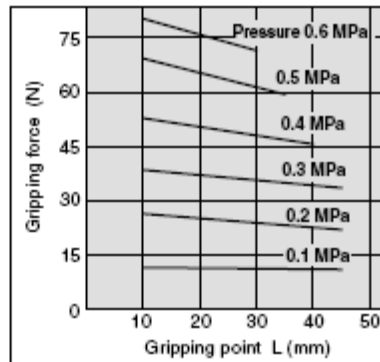

MHS4-40D

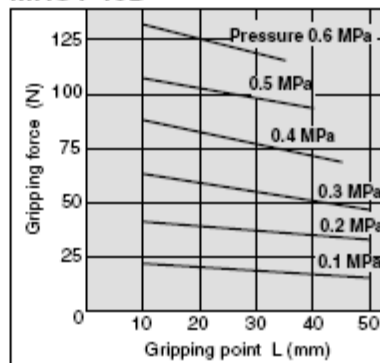

MHS4-50D

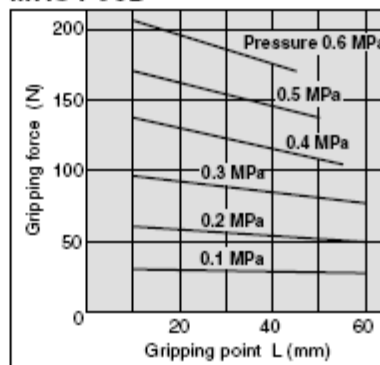

MHS4-63D

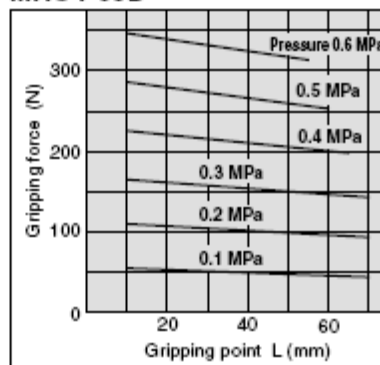

4 Finger Parallel Style Air Gripper Series **MHS4**

Dimensions

MHS4-16D to 25D

2- ϕ 3.4, counterbore dia. 6.5

Counterbore depth SC (Mounting hole)

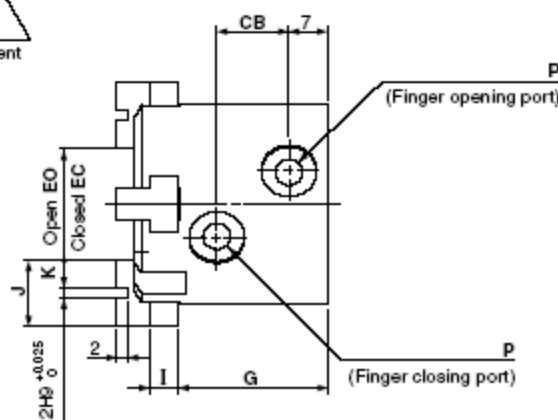
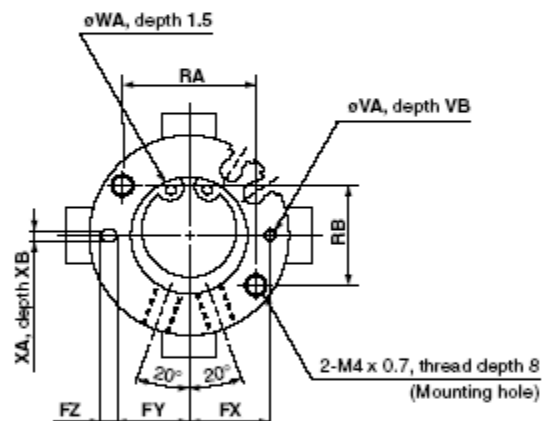
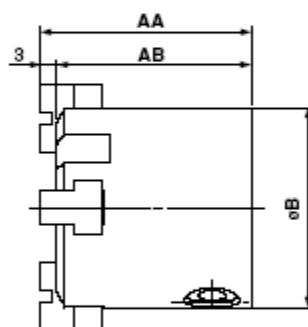
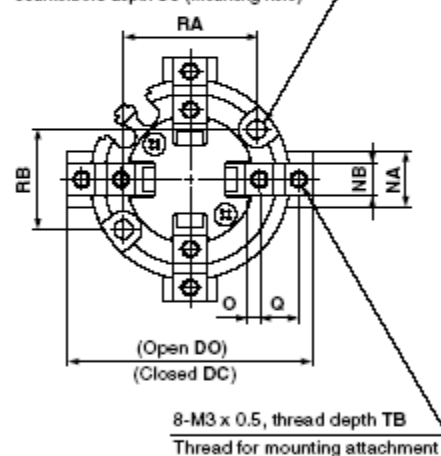

Auto switch mounting groove dimensions (2 locations)

MHS4-16D

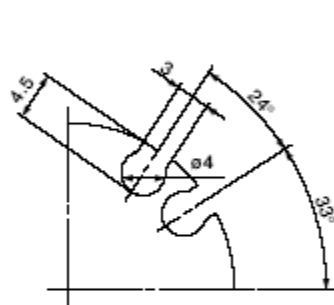

MHS4-20D

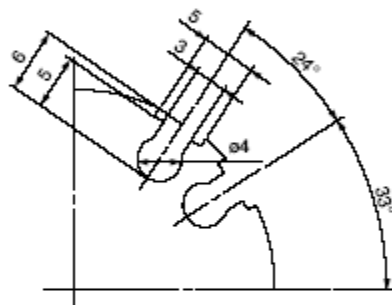

MHS4-25D

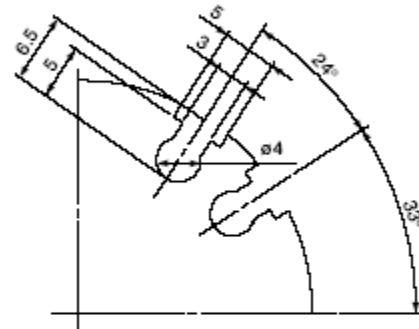

Model	AA	AB	B	CB	DC	DO	EC	EO	FX	FY	FZ	G	I	J	K	NA	NB	O	P	Q
MHS4-16D	35	32	30	11	33	37	13	17	12.5	11	3	25	4	10	4	8	5h9 ₀ ⁰ _{-0.030}	2	M3 x 0.5	6
MHS4-20D	38	35	36	13	39	43	15	19	14.5	13	3	27	5	12	5	10	6h9 ₀ ⁰ _{-0.030}	2.5	M5 x 0.8	7
MHS4-25D	40	37	42	15	48	54	20	26	17	14.5	5	28	5	14	6	12	6h9 ₀ ⁰ _{-0.030}	3	M5 x 0.8	8

Model	RA	RB	SC	TB	VA	VB	WA	XA	XB
MHS4-16D	18	16	8	5	2H9 ₀ ^{+0.025}	2	17H9 ₀ ^{+0.043}	2H9 ₀ ^{+0.025}	2
MHS4-20D	24	18	9.5	6	2H9 ₀ ^{+0.025}	2	21H9 ₀ ^{+0.062}	2H9 ₀ ^{+0.025}	2
MHS4-25D	26	22	10	6	3H9 ₀ ^{+0.025}	3	26H9 ₀ ^{+0.062}	3H9 ₀ ^{+0.025}	3

MHZ

MHF

MHL

MHR

MHK

MHS

MHC

MHT

MHY

MHW

MRHQ

Misc.

D-

20-

Series MHS4

Dimensions

MHS4-32D/40D

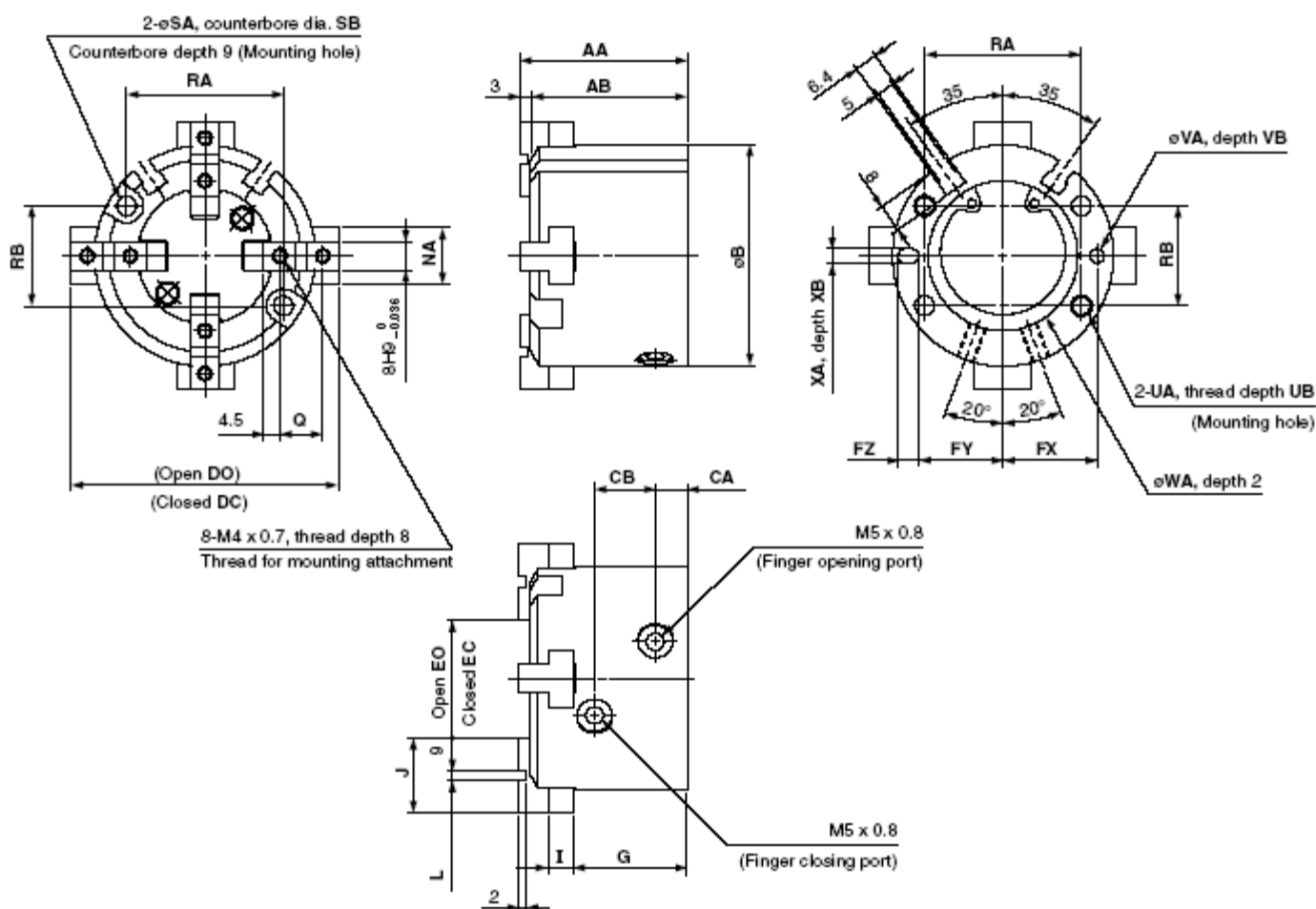

Series MHS4 Detailed dimensions of mounting portion of end plate

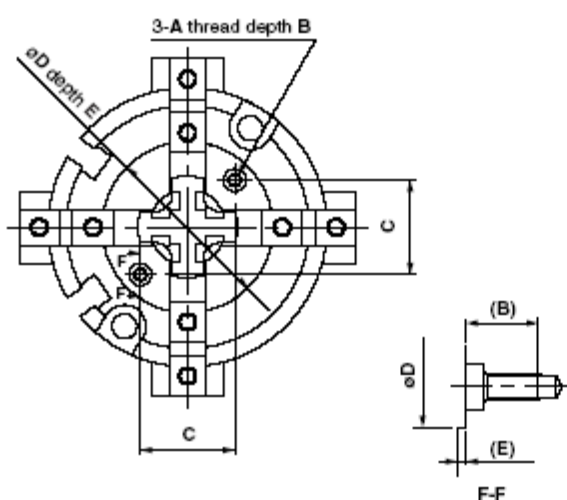

Model	A	B	C	øD	E
MHS4-16D	M2 x 0.4	5.5	11	21	0.5
MHS4-20D		5.4	13	24	0.6
MHS4-25D			15	27	
MHS4-32D	M3 x 0.5	5.2	18	32	0.8
MHS4-40D		8		21	38
MHS4-50D			24	42	
MHS4-63D			32	54	

Model	AA	AB	B	CA	CB	DC	DO	EC	EO	FX	FY	FZ	G	I	J	L	NA	Q	RA	RB	SA	
MHS4-32D	44	41	56	8	16	60	68	20	28	23	20.5	5	30.5	6	20	2H9 ₀ ^{+0.025}	14	11	38	25	4.5	
MHS4-40D	47	44	62	9	17	66	74	24	32	26.5	23.5	6	32	7	21	3H9 ₀ ^{+0.025}	16	12	44	28	5.5	
Model	SB	UA	UB	VA	VB	WA	XA	XB														
MHS4-32D	8	M5 x 0.8	10	3H9 ₀ ^{+0.025}	3	34H9 ₀ ^{+0.062}	3H9 ₀ ^{+0.025}	3														
MHS4-40D	9.5	M6 x 1	12	4H9 ₀ ^{+0.030}	4	42H9 ₀ ^{+0.062}	4H9 ₀ ^{+0.030}	4														

(mm)

4 Finger Parallel Style Air Gripper Series MHS4

MHS4-50D/63D

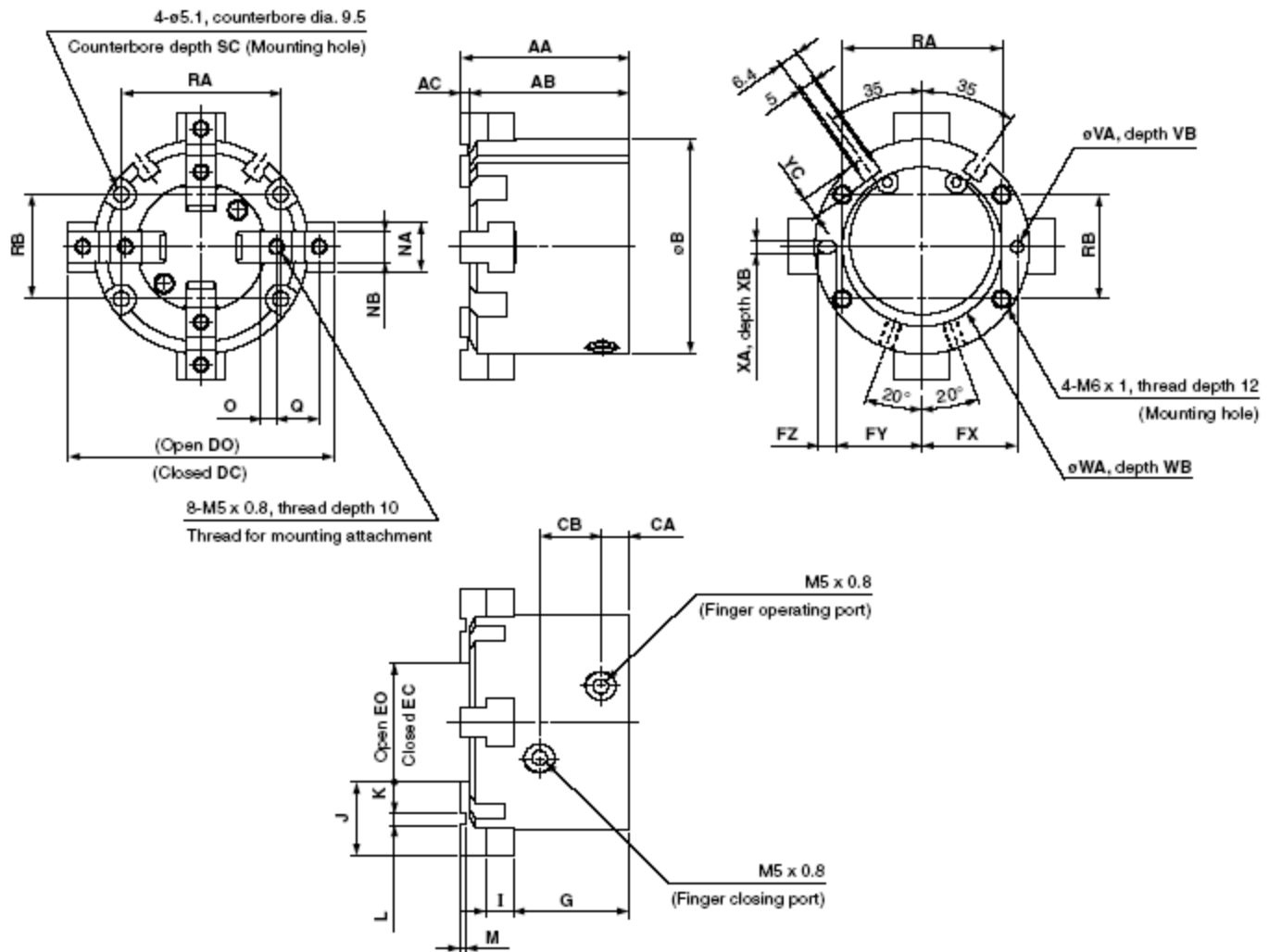

MHZ

MHF

MHL

MHR

MHK

MHS

MHC

MHT

MHY

MHW

MRHQ

Misc.

D-

20-

(mm)

Model	AA	AB	AC	B	CA	CB	DC	DO	EC	EO	FX	FY	FZ	G	I	J	K	L	M	NA	NB
MHS4-50D	55	52	3	70	9	20	74	86	26	38	31	28	6	37.5	9	24	10	4H9 ^{+0.030} ₀	2	18	10h9 ⁰ _{-0.036}
MHS4-63D	66	62	4	86	12	22	91	107	35	51	38	34.5	7	44	11	28	11	6H9 ^{+0.030} ₀	3	24	12h9 ⁰ _{-0.043}
Model	O	Q	RA	RB	SC	VA	VB	WA	WB	XA	XB	YC									
MHS4-50D	5	14	52	34	12	4H9 ^{+0.030} ₀	4	52H9 ^{+0.074} ₀	2	4H9 ^{+0.030} ₀	4	7									
MHS4-63D	5.5	17	66	38	14	5H9 ^{+0.030} ₀	5	65H9 ^{+0.074} ₀	2.5	5H9 ^{+0.030} ₀	5	7.5									